

Sportsman SXS Technical Specifications

Class Definitions and Overview

Sportsman SXS - Stock up to 1000 cc SXS rules are outlined below. It is the intention that all modifications allowable are outlined below and all other parts/ components that can affect or enhance the performance of the vehicle must remain stock. The Technical Director holds final decision-making power on any stock/ non-stock component deemed legal or illegal to race.

SXS-1 VEHICLE SIGNAGE

- A. Advertising on race vehicles must be in good taste.
- B. USAC may require the use of specific sponsor decals.
- C. Team vehicles with the same paint and colors must have prominent distinguishing markings of some kind. Tech Director reserves the right to require additional markings to help distinguish between vehicles.

SXS-2 NUMBERS AND STICKERS

- A. Numbers are ~~700-799~~ **0 - 99** for the Sportsman SXS class.
- B. Numbers must be applied side by side. No slanted numbers.
- C. Number plates must be ~~white~~ **yellow** with solid black block style numbers.
- D. All vehicle numbering is assigned by USAC.
- E. USAC officials may require a competitor to use a different number to avoid confusion or duplication at an event.
- F. In the event that a number is not visible from the timing and scoring area, the competitor will not be scored. It is the competitor's responsibility to make sure that the number is visible during all race conditions.
- G. Foil or reflective numbers are not permitted.
- H. All USAC vehicles are required to have USAC stickers on each side of the front of the door area, 4" down from the window opening.
- I. One number on each side of the vehicle, on a number plate mounted high and close to the back of the roof. Minimum number plate size: 10" high by 14" long. Minimum number size: 8" x 1 1/2".

- J. The back of the vehicle facing the rear, on a number plate:
Minimum number plate size: 6" high by 8" wide. Minimum number size: 5" x 1 ½"
- K. Roof: Minimum number size: 8" x 1 ½".
- L. Upper left-hand corner of windshield area:
- M. Minimum number size 4".

SXS-3 ROLL CAGE AND CHASSIS

- A. All vehicles must utilize the stock chassis and maintain stock appearance. The stock chassis (frame) is defined as the main lower rails running along the inner sides of the SXS and the front and rear tubes that connect them. The chassis may be modified for durability and strength but must retain the stock width, length, and configuration. Any modifications must be pre-approved by USAC officials.
- B. **No carbon fiber or titanium materials allowed in chassis or body construction. CF and Ti allowed in engine configuration, only if produced OEM. Carbon fiber may be used in exhaust mufflers, cans, and resonators.**
- C. After market roll cage required. **Bolt-on or weld-on cages are permitted. If weld-on style, weld joint must be within 6" of stock junctions.**
- D. Cages must be constructed with one front vertical hoop, one rear vertical hoop, two Inter-connecting top bars, two rear down braces, one diagonal brace, and all necessary gussets. Welded "B pillar" connection points are permissible.
- E. Two top interconnecting bars must be placed as far to the outside of the top part of the front and rear hoops as possible.
- F. Rear down braces and diagonal brace must angle a minimum of 30 degrees from vertical. At the bottom of the diagonal brace there must be a cross member of the same tubing material and dimensions as the hoop.
- G. There must be a minimum of 3" clearance between driver's helmet and roll cage.
- H. Gussets must be installed at all major intersections, including diagonal and rear down braces, where single weld fractures can affect occupant's safety.
- I. Gussets may be constructed of minimum .090" x 3" x 3" flat plate or tubing gussets made of same material and thickness as roll cage.

- J. Roll cage terminal ends must be attached to a frame or body member that will support maximum impact and not shear or allow more than 1 ½" of movement in the cage terminal end.
- K. Minimum tubing diameter and thickness is 1 ½" diameter by .095.
- L. Roll cage material must be DOM or 4130 chromoly.
- M. All tubing, welds, gussets, and roll cage construction must be approved by USAC.
- N. Entire roof must be covered with sheet metal or .063" minimum aluminum.
- O. Top left half of roll cage above driver's head must have one 1 ½" x .095" diagonal bracing bar.
- P. It is recommended that stock cage and seat belt mounting plates be reinforced, especially on Pre-2012 vehicles.
- Q. **Rear Firewall: Firewall must be as high/tall as harness bar. Stock plastic is allowed, but competitors are encouraged to use .063" aluminum minimum.**

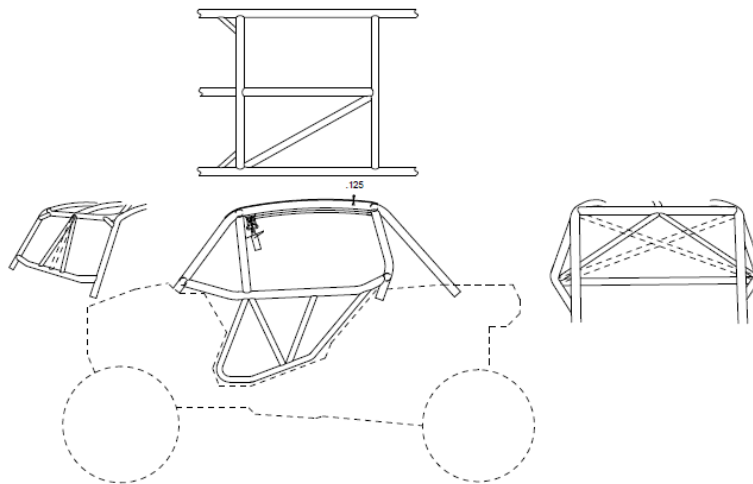

SXS-4 DOORS

- A. Door area must be covered with sheet metal or a minimum of .063" thick aluminum. Panel must be attached with bolts or dzus buttons.
- B. **Door top tube must be a minimum of 1 ½" diameter X .095 wall thickness DOM, or 4130 Chromoly.**
- C. **Doors must have a A, V or X design to protect drivers area.**
- D. **Lower U shape tube and all A, V or X designs must use a minimum 1 ¼" diameter by .095, 4130 chromoly or DOM.**

SXS-5 DRIVER COMPARTMENT

- A. Driver must be able to enter and exit, unassisted and with great ease, the driving compartment with the vehicle in any position. Firewalls and/or bulkheads must separate the driving compartment from any fuels, engine fluids, and acids.
- B. Driver's seat must be in stock location and be bolted in. Seat may be lowered. Race seat is required. ~~Must meet SFI Requirements.~~ **If it does not meet SFI 39.2 standard, it is subject to approval by TORC / USAC.** If no passenger seat is used, gas tank area must be completely covered with aluminum firewall.
- C. A 5-point motorsports specific harness is mandatory. It must be in spec with the manufacturer's date tag.
- D. **Driver side window net is mandatory, and must be latch style, no spring loaded design bars allowed. construction must be 1/2" solid steel rod.**
- E. Reinforced floor pan is recommended.
- F. **Rock screens must cover entire area in front of driver.**
 - 1. **Construction to be a minimum of .120 rod and rod spacing shall be no greater than a maximum 1.5" opening.**

SXS-6 MEASUREMENTS AND WEIGHTS

- A. All measurements will be performed with USAC technical instruments and gauges. USAC officials determine all measurements and center points.
- B. Minimum vehicle weight: 1650 lbs. with driver (RZR, Arctic Cat, Can-Am), 1750 lbs. with driver (Yamaha)
- C. All ballast must be securely mounted with at least two 5/16" bolts with locknuts that are wired or pinned.

SXS-7 BODY & FENDERS

- A. Fenders must be securely attached to vehicle. The removal of fenders during competition during any reason other than damage incurred during the race will result in disqualification.
- B. Fenders must be attached in such a fashion as not to create a pointed or sharp extrusion when removed. A loop body mounting bracket construction is mandatory.
- C. Additions to the body of the race vehicle, such as fins, scoops, wings, and other extruding additions will not be permitted.

- D. Vehicles must maintain an appearance similar to the stock SXS.
 - 1. **Must retain all bed plastics and panels.**
 - 2. **Hoods must remain stock and mounted exactly in the stock location.**
- E. All body panels must be stock or aftermarket stock replacement.

SXS-8 BUMPERS

- A. Vehicles must have front and rear bumpers. USAC officials must approve all bumpers.
- B. **Bumpers must be designed in such a way as to inhibit two vehicles from becoming locked together.**
- C. **Ends must be capped and rounded with no sharp edges.**
- D. **All classes are to have side nerf bars.**
 - 1. **Nerf bar to be a minimum 1" diameter mild steel.**
 - 2. **Must be as wide as centerline of tire or wider from front of vehicle to back.**
 - 3. **Must be capped and rounded, no sharp edges exposed.**
 - 4. **Distance of protection must be no greater than 12" from rear tire.**

SXS-9 SKIDPLATES AND FLOORBOARDS

- A. Skid plates designed to reasonably protect the front suspension, steering, and brake components are recommended on all vehicles. Plates must be made of metal and be securely attached.
- B. Stock SXS floorboards are acceptable but extra protection made of metal or aluminum is highly recommended.

SXS-10 SUSPENSION

- A. All A-arm mounting points must remain in the stock location and position as delivered from the manufacturer, however they may be reinforced for strength.
- B. Must maintain Factory "Stock" Track Width
- C. Must maintain Factory "Stock" Wheel Base
- D. **Control arms must remain stock lengths.**
- E. **Wheel spacers are NOT allowed in any class.**
- F. **Minimum ride height of 8" as determined by technical inspector.**
- G. **Aftermarket sway bars are permitted.**

SXS-11 STEERING

- A. All steering components must be in good condition and proper working order. Drag link and tie rod ends must be secured with a cotter pin in each one.
- B. Power steering is permitted.
- C. Steering “quickeners” are permitted in the Sportsman UTV class.
- D. USAC officials must consider steering reasonably safe before vehicle is permitted to compete.

SXS-12 SHOCKS

- A. There must be at least one and only one shock absorber per wheel in working condition at the start of the race.
- B. Shock absorber mounting points may NOT be moved.
- C. Upper shock mounts must remain in stock location. No bolt on extensions. No bypass shocks.
- D. BUMP STOPS - Suspension bump stops must be of the solid type.
- E. TORSION SYSTEM - The only torsion system that is acceptable is a coil-over shock.

SXS-13 BRAKES

- A. Brakes must be in safe working condition and be able to apply adequate force to lock up all four tires.
- B. Brakes must remain in safe working condition during entire event.
- C. Turning or cutting brakes are not permitted.

SXS-14 ENGINE

- A. All vehicles must use stock engine cases and cylinder head. USAC reserves the right to mark engine blocks prior to event.
- B. All vehicles must use same fuel delivery system as stock and designed by factory.
- C. Electric fuel pumps are permitted in accordance with USAC safety requirements for fuel pumps.
- D. Engine displacement not to exceed 1000 cc.
- E. Engines must remain completely stock. No internal modifications. Stock throttle body must be used.
- F. **ECU – Must maintain factory OEM ECU. NO tunes allowed.**

SXS-15 SUPERCHARGERS & TURBOCHARGERS - Superchargers or turbochargers are NOT permitted in Sportsman SXS class.

SXS-16 AUXILLARY EQUIPMENT - All vehicles must start race with a functional generator or alternator, fan, water pump (water- cooled vehicles), and a complete functional electrical system.

- A. **GPS is allowed.**

SXS-17 IGNITION

- A. **All vehicles must use a stock ignition switch or have a positive action on/off switch in good working order. Switch must be labeled "ignition on/off", have a red circle around it, be located on the left-hand side of the dash panel, and must be accessible from the outside of the race vehicle. Red locator decal/circle must be at least 1" wide around switch.**
- B. All electric fuel pumps with independent switches must be labeled "fuel on/off" and be within easy reach of the driver and accessible from the outside of the vehicle.
- C. Aftermarket CDI boxes/ECUs are NOT permitted.

SXS-18 BATTERIES

- A. Batteries must be securely mounted with metal-to-metal tie downs.
- B. Wetted fiber or gel cell batteries only. Liquid lead acid batteries are not permitted.
- C. Batteries may be located in the driver's compartment with an adequate firewall or factory engine cover.

SXS-19 COOLING

- A. Oil coolers, transmission coolers, and radiators located ahead of the driver, **behind the cockpit** or in the passenger compartment must have a shroud that will prevent liquids from blowing back or leaking onto the driver in the event of a rupture or leakage. **All radiator caps must be shielded from driver.**
- B. All hoses running through the driver compartment must be shielded. Steel braided hose does not constitute a shield.

SXS-20 EXHAUST

- A. Aftermarket exhaust is NOT allowed. Exhaust must remain stock.

SXS-21 STARTER - All vehicles must be self-starting by use of an onboard electric starter.

SXS-22 ENGINE REPLACEMENT

- A. Engines may be replaced during a USAC event only if competitor has notified USAC officials.
- B. Engine change will result in a starting position change.

SXS-23 FUEL - VP Racing Fuel T4 will be the spec fuel for ALL SXS classes in 2018.

SXS-24 FUEL CELLS

- A. All fuel cells must be USAC approved.
- B. USAC will reject any previously approved fuel cell, which appears to be defective, damaged, or not in proper condition.
- C. No pressure systems will be allowed. Any concealed or not concealed pressure type containers, feed lines or actuating mechanisms will not be permitted, even if inoperable.
- D. Icing, Freon type chemicals, or refrigerants may not be used in or near the fuel system.
- E. The use of a commercially manufactured fuel cell is mandatory. Aluminum cans with foam inside are not allowed.
- F. Safety fuel cells shall consist of a bladder enclosed in a smooth skinned container. The container shall be constructed of 20 gauge steel, 0.060" aluminum or 0.125" Marlex. Rotary molded polymer cells are acceptable.
- G. No material other than standard foam as provided by the fuel cell manufacturer is permitted.
- H. Fuel cell must have a chassis or body cross member of substance between the fuel cell and driver and be protected from ground obstacles.
- I. Fuel cells must be dated from manufacturer. Fuel cells will become obsolete five years after date of manufacture and must be replaced
- J. All fuel cell fillers and vents must have check valves installed.
- K. Fuel filler lines and positive-locking non-vented fuel filler caps must be located and secured in such a manner as to prevent them from being knocked off or opened during movement, rollover, or impact.
- L. A splash shield must be in place to direct any spill away from the driver, motor, and motor exhaust. A body panel is considered a sufficient splash shield.
- M. Fuel cell cannot be vented into the driver's compartment of any vehicle.
- N. All mountings must be USAC approved. Fuel cell must be mounted to chassis and cannot be mounted on skid plate.
- O. Any fuel cell mounted in the passenger compartment area must be fully enclosed with sheet metal or aluminum.
- P. An 8" x 8" fire access door is required on top of the fuel cell cover. This door must be painted red and labeled FIRE DOOR.

- Q. Any battery or electrical components mounted in the passenger compartment with the fuel cell must be separated by sheet metal or aluminum.
- R. Stock fuel tank is allowed in stock location. Tank, lines and fuel filler may not be modified in any way. Aluminum plate must be added on right outer side of body to protect stock tank.

SXS-25 FUEL VENT ROUTING

- A. All fuel cell vents and lines must come out of the top of the fuel cell
- B. Fuel shall be automotive gasoline only.
- C. Gasoline shall not be blended with alcohols, ethers, or other oxygenates, and it shall not be blended with aniline or its derivatives, nitrous compounds, or their nitrogen containing compounds.
- D. Cooling of any type of fuel is not permitted during competition.
- E. In the event an "official fuel" is named, USAC will sample the actual fuel provided at the track by the fuel supplier and that sample will become the benchmark from which all competitors samples will be judged.
- F. USAC has the right to sample a competitor's fuel at any time. All samples will be impounded for observation and/or testing by USAC or outside laboratories at USAC discretion.
- G. No nitrous oxide.
- H. If USAC officials suspect maskers in the fuel, chemical testing will be conducted at possible expense to the competitor.
- I. Penalties for use of hazardous chemicals will be severe including fine, and/or reduction of points, and/or suspension.

SXS-26 TRANSMISSION

- A. Every vehicle must use the stock transmission and clutch design.
 - 1. **CVT transmissions: OEM gears allowed. (No aftermarket or performance gear sets.)**
 - 2. **Yamaha YXZ vehicles must use OEM gear ratios and flywheel.**
- B. The stock rear differential must also be used.
- C. All vehicles must have a functional reverse gear.

SXS-27 CLUTCH

- A. Must use stock clutch design as delivered from manufacturer.
 - 1. **Yamaha: Coil spring conversion is allowed.**
- B. No billet clutches **or aftermarket clutches**. Clutches may not be modified in any way.
- C. After market springs, weights and helix are allowed.
- D. **Factory paddle shifters as delivered from factory are allowed. No retrofitting to other years, makes or models.**

SXS-28 WHEELS AND TIRES

- A. Maximum tire size is 30" outside diameter.
- B. No more than 1 tire per corner is permitted.
- C. Tires will be visually checked and must be considered reasonably safe by USAC prior to competing.
- D. **Bead locks allowed, must have recessed bolts only that do not protrude past the face of the clamp ring, or must use button head style bolts.**
- E. **Any wheel offset combination is permitted.**

SXS-29 FASTENERS

- A. All components on the vehicle's suspension system, chassis, and running gear must be secured with S.A.E. Grade 8 or better nuts and bolts.
- B. Bolts must be secured with either lock nuts, lock washers, cotter pins, or safety wire and have at least one full thread showing through the nut.

SXS-30 **HOSES** - All fuel and brake line hoses including metal lines and fittings must be clamped and/or safety wired.

SXS-31 **MIRRORS** - Rear view mirror with at least 6 square inches of mirror surface and a reasonably unobstructed view of area behind vehicle is recommended on all vehicles.

SXS-32 TRANSPONDERS/TIMING

- A. Remote score timing devices will not be permitted by teams, owners, or anyone associated with an entry, unless approved by USAC.
- B. All teams are required to purchase remote timing transponders. Transponders can only be purchased through USAC and numbers must be recorded with USAC officials.
- C. Drivers are responsible for the charging and installation of all transponders. Any entry without a properly installed, functioning transponder may not be scored and may be subject to further penalty.
- D. **Transponders must be mounted 10" back from the leading edge of the front bumper and a maximum of 15" in height with a clear view to the track surface.**

SXS-33 DUST LIGHT

- A. **A minimum of one rear dust light is required.**
- B. **The light must be an amber LED with a round 2.5" diameter, or rectangular with a 2" x 6" dimension minimum.**

**Kyle Robbins
USAC Tech Director**